

6 5 4 3 2 1

D

D

C

C

B

B

A

A

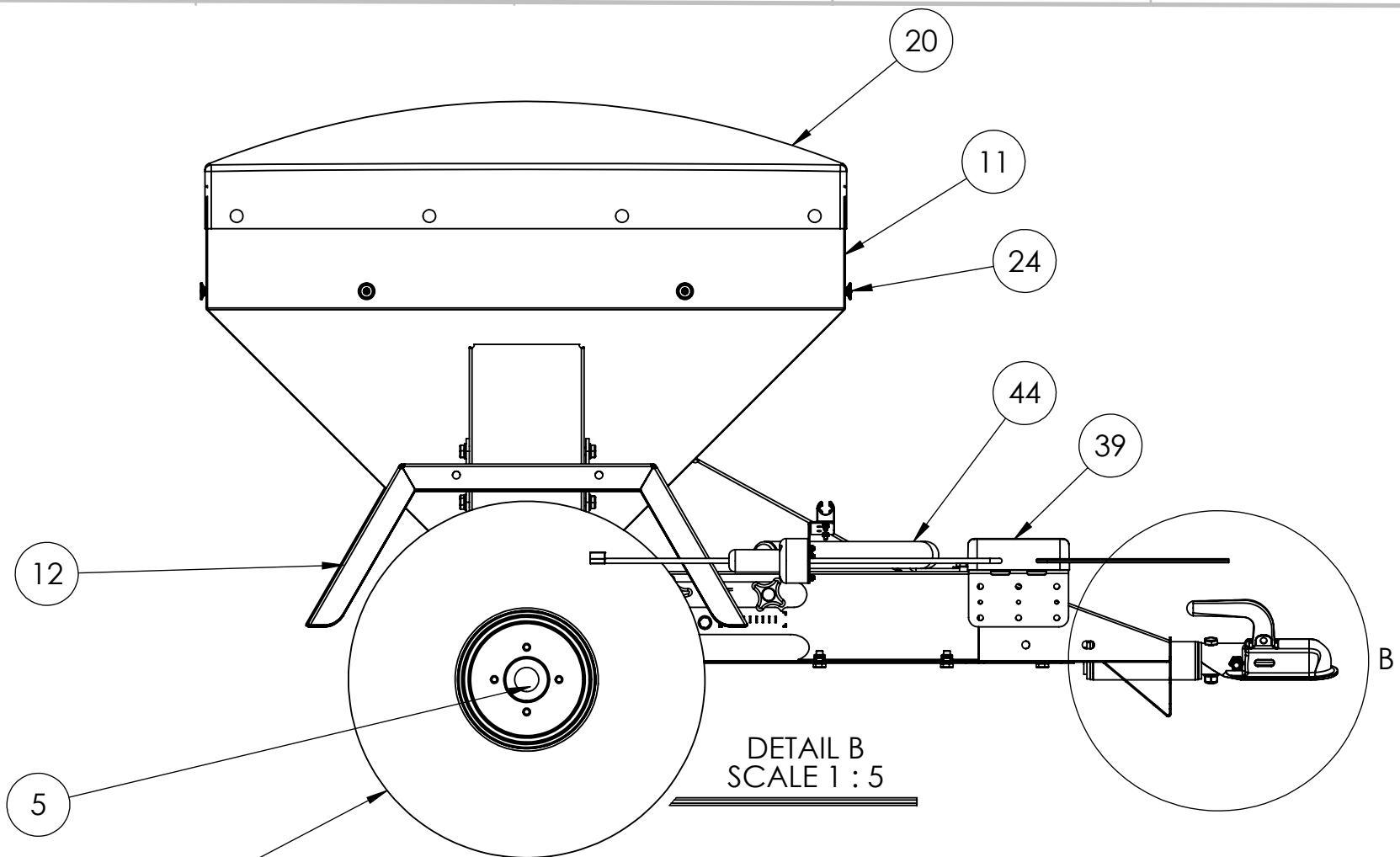

DETAIL B
SCALE 1 : 5

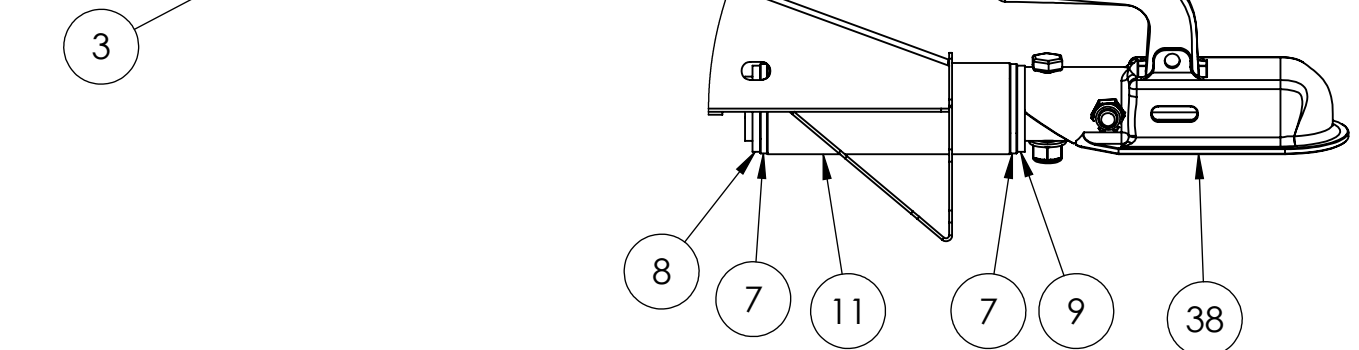

MODEL:	TF350
YEAR/ MARK:	09/2014 ONWARDS
SHEET 1 OF 7	

6 5 4 3 2 1

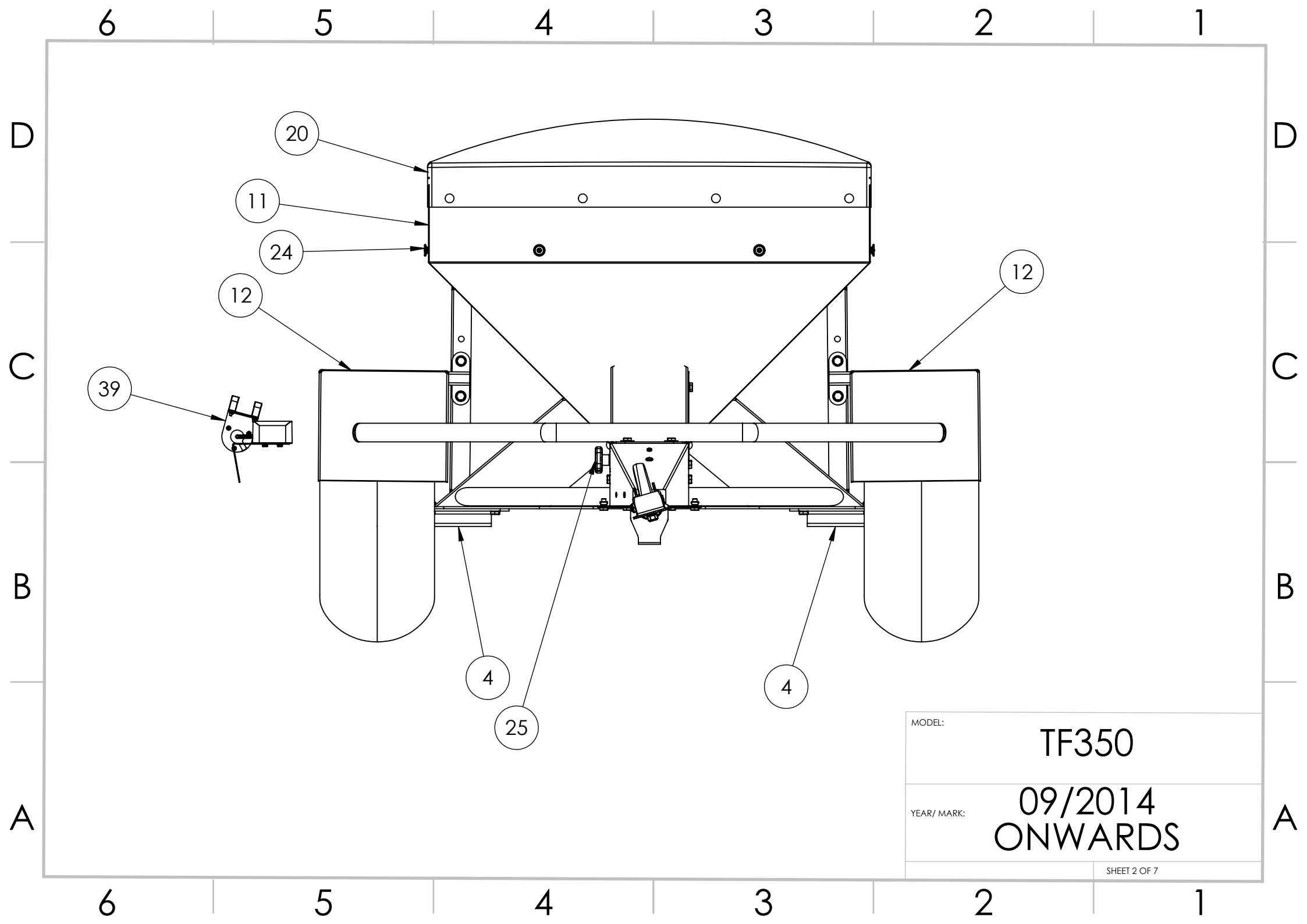

MODEL:	TF350
YEAR/ MARK:	09/2014 ONWARDS
SHEET 2 OF 7	

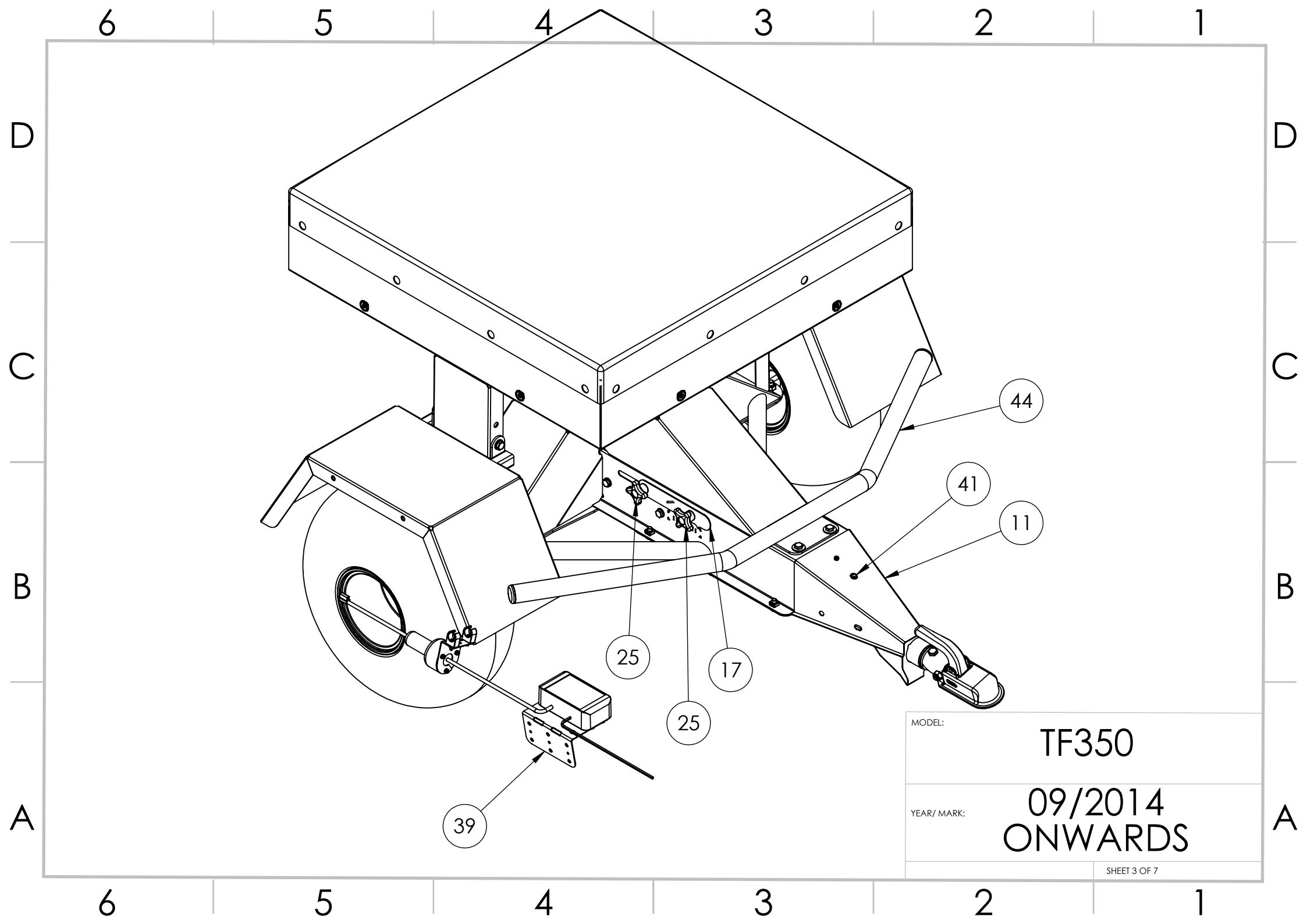

MODEL:	TF350
YEAR/ MARK:	09/2014 ONWARDS

DETAIL A
SCALE 1:2

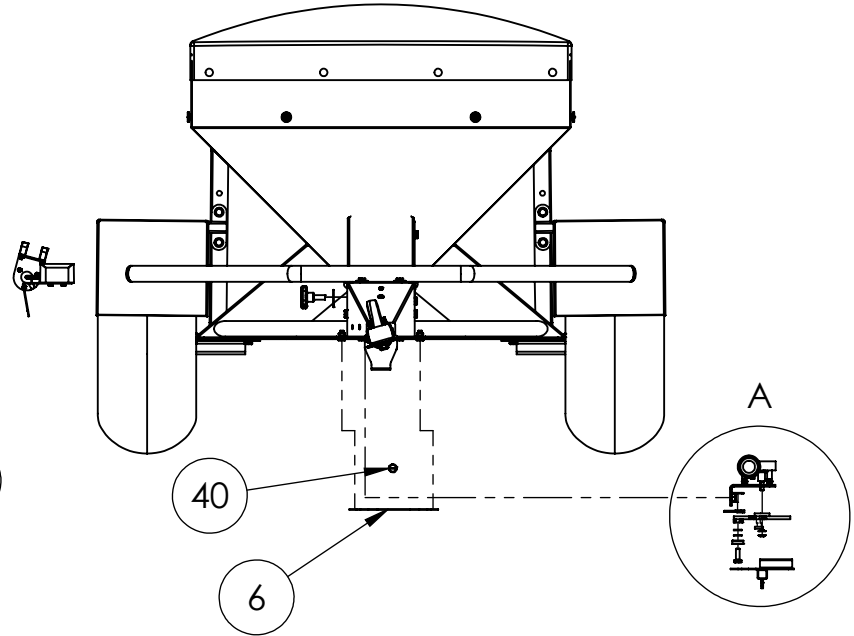
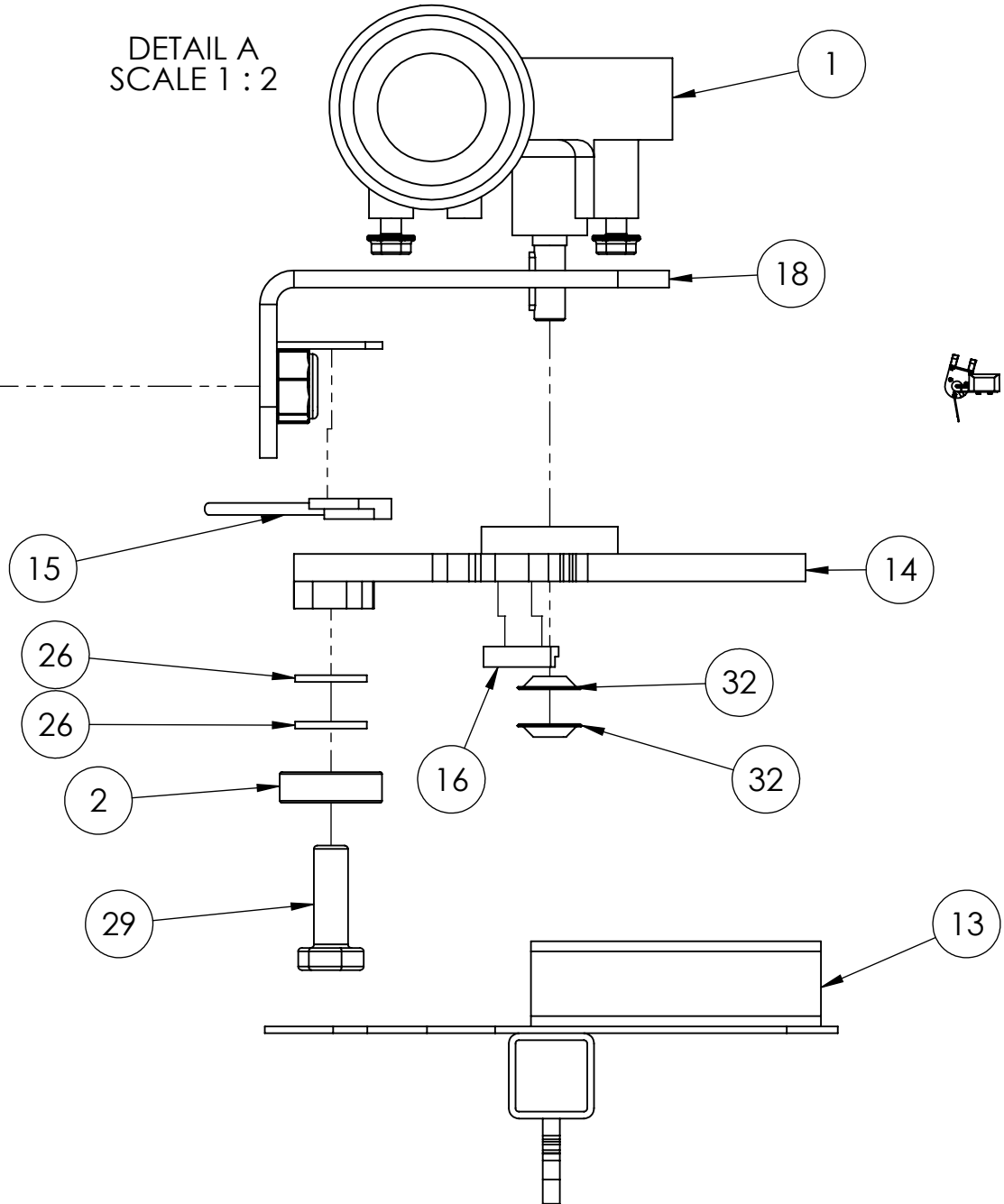

MODEL:	TF350
YEAR/ MARK:	09/2014 ONWARDS
SHEET 4 OF 7	

6

5

4

3

2

1

ITEM NO.	PART NUMBER	DESCRIPTION	Standard Axle/QTY.
1	11137632000	DOGA MOTOR 111.3763.20.00 25RPM 12V	1
2	6200-2RSH	BEARING, BALL, 10MM ID 30MM OD	6
3	WAT-22118W	22X11X8 WHEEL ASSEMBLY 4X4" PCD	2
4	TF350-SAS	STANDARD AXLE ASSEMBLY, TF350	2
5	ADR-200H	HUB 4X4" SSP	2
6	TF350-009	BASE COVER PLATE	1
7	SH-002	SWIVEL HITCH BUSH	2
8	SH-001	SWIVEL HITCH DRAWTUBE ASSEMBLY	1
9	SH-003	SWIVEL HITCH WASHER 44MM ID 60MM OD 5MM THICK	1
10	TF350-007	DRIVE COVER PLATE REV D	1
11	TF350-MFA	MAIN FRAME ASSEMBLY, TF350	1
12	TF350-MGA	MUD GUARD ASSEMBLY, TF350	2
13	TF350-SPA	SLIDE PLATE ASSEMBLY, TF350	1
14	TF350-RPA	ROTATION PLATE ASSEMBLY, TF350	1
15	MMPSA 240-30 LH	SENSOR, MMPSA 240/30	1
16	MMPSM	MMPSM MAGNET TO SUIT SENSOR MMPSA 240/30 LH	1
17	TF350-013	DROP INDICATOR PLATE REV B	1

MODEL:

TF350

YEAR/ MARK:

09/2014
ONWARDS

SHEET 5 OF 7

6

5

4

3

2

1

D

D

C

C

B

B

A

A

		6	5	4	3	2	1
D	ITEM NO.	PART NUMBER	DESCRIPTION				Standard Axle/QTY.
	18	TF350-MMP	MOTOR MOUNT PLATE ASSEMBLY				1
	19	TF350-CSA	COVER SUPPORT ASSEMBLY				1
C	20	TF350-TARPAULIN	TARPAULIN, TF350, 1010MM X 1010MM X 100MM, ORANGE PANAMA PVC 900G WITH BLACK CORD AND 16 EYELETS				1
	21	M5-20PP	M5 x 20 Pan Head Pozi Screw				10
	22	M5-000PW	M5 Plain Washer Form A				12
	23	M5-000NN	M5 Nylock Nut				10
	24	MP995B	TRAILER BUTTON CLEAT, BLACK PLASTIC				8
	25	F189-60 M12	HAND WHEEL, M12, 30MM THREAD				2
	26	M10-000PW	M10 PLAIN WASHER FORM A				24
	27	M12-000PW	M12 PLAIN WASHER FORM A				17
	28	M10-000NN	M10 NYLOCK NUT				5
	29	M10-30HB	M10 x 30 Hex Head Bolt				1
B	30	M10-000CN	M10 Cage Nut				12
	31	M10-20HB	M10 x 20 Hex Head Bolt				10
	32	BV6708	9mm Starlock Shaft Washer				2
	33	M12-30HB	M12 x 30 Hex Head Bolt				16
	34	M12-000NN	M12 NYLOCK NUT				18
A						MODEL:	TF350
						YEAR/ MARK:	09/2014 ONWARDS
						SHEET 6 OF 7	
		6	5	4	3	2	1

6

5

4

3

2

1

ITEM NO.	PART NUMBER	DESCRIPTION	Standard Axle/QTY.
35	M10-40HB	M10X40 HEX HEAD SET SCREW	5
36	M12-60HB	M12X60 HEX HEAD BOLT	1
37	M12-70HB	M12X70 HEX HEAD BOLT	1
38	8802429X	8802429X COUPLING 50MM BALL TO SUIT 43MM TUBE	1
39	TF350-CA	CONTROL BOX ASSEMBLY, TF350, COMPLETE	1
40	E7707650	SPRING, 140MM, 21.59MM DIA, 2.18MM WIRE, 0.67N/M	1
41	498047	RUBBER GROMMET, PVC, 10MM ID, 16MM OD, 7MM THICK, 12MM HOLE DIA	2
42	SERIALPLATE	SERIAL PLATE CHAPMAN	1
43	1862	NYLON P CLIP. CLEAR, 5.5MM CABLE DIA	2
44	TF350-NB	TF350 NUDGE BAR OPTION	1

MODEL:	TF350
YEAR/ MARK:	09/2014 ONWARDS
SHEET 7 OF 7	

6

5

4

3

2

1

D

D

C

C

B

B

A

A